



CT16-Rotate

Including signal conditioning for strain gage, thermo couples, Pt100, ICP, POT and high-level inputs

User manual



with diversity receiver unit

General functions:

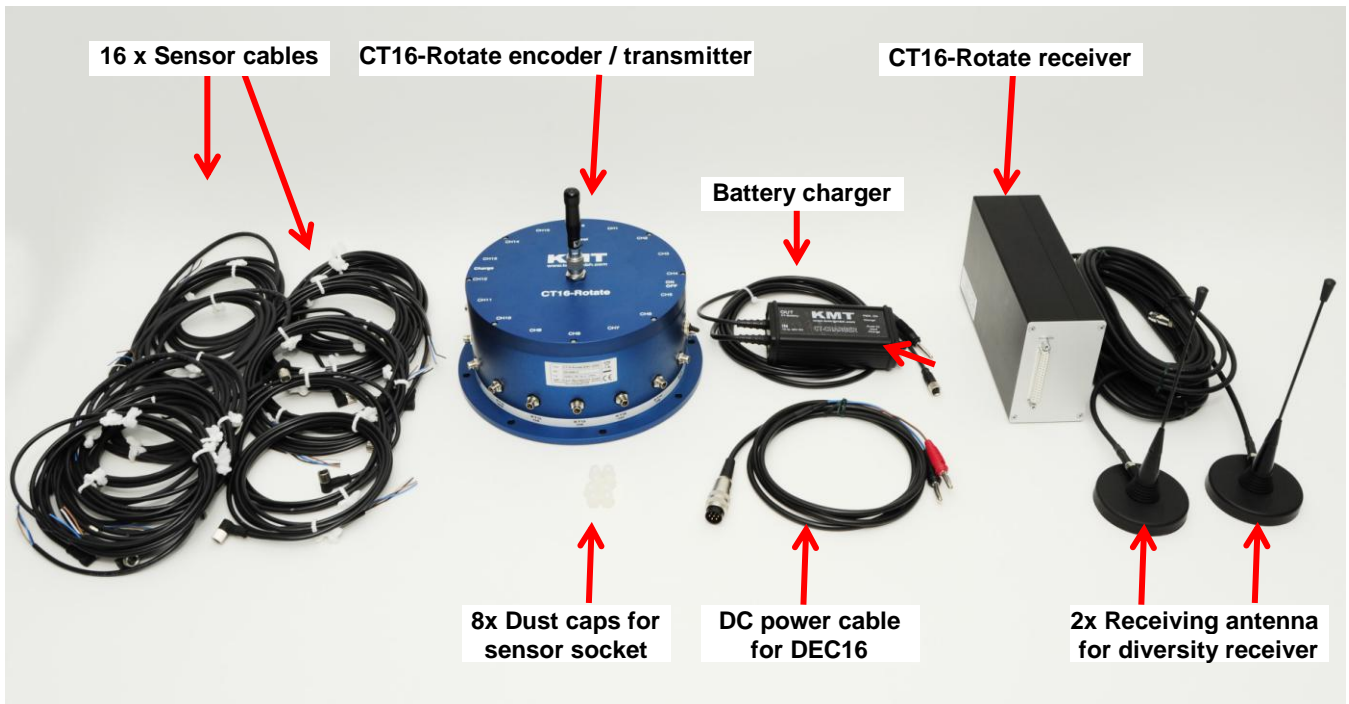

The CT16-Rotate is a 16-channel telemetry system for rotating application with integrated signal conditioning for sensors, wireless digital transmission and analog reproduction.

The conditioned measured values are routed via anti-aliasing filter to a 12-bit A/D converter, simulate sampling of all channels, encoded in PCM format and transferred to the HF transmitter as modulation variables. Dynamic range is 72dB with a signal-to-noise ratio of approximately 70dB. Different carrier frequencies available with the Various configurations of different sensor modules are possible like signal conditioning for strain gages (STG), thermocouples type K (Th-K), thermo sensors Pt100, ICP sensors, potentiometer sensors (POT) and also Voltage inputs (+/-5 or +/-10V). Mixed configuration available.

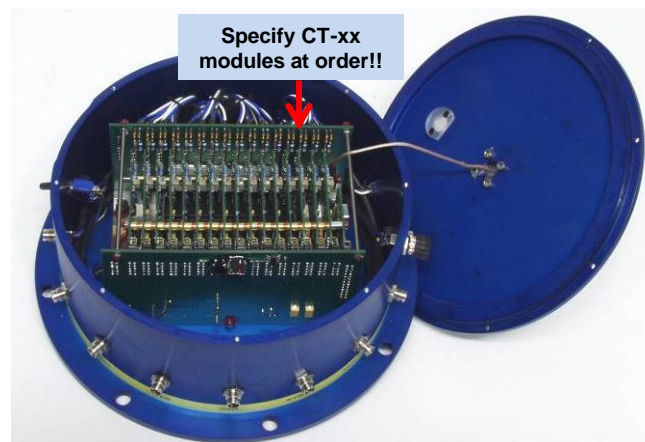

Frequency table	Cut off frequency from anit-aliasing filter (-3dB) and scanning rate (see red)
Bit rate	16 CH.
1280kbit	1500Hz (6530Hz)
640kibt	750Hz (3265Hz)
320kbit	375Hz (1632Hz)

Different applications:



CT16-Rotate Transmitting Unit Technical Data (Encoder)



Encoder in IP65 Aluminum housing

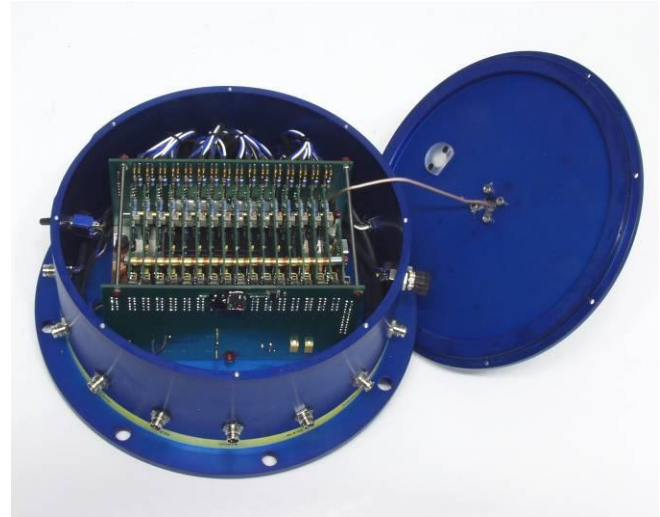

Encoder inside

CT-STG V1:

Sensor:	strain gage, ≥ 350 Ohms
Bridge completion:	full, half and quarter-bridge competition 350Ohm
Excitation:	4 VDC (fixed), short-circuit protection up to 20mA
Gain:	200 or 1000 - selectable by solder jumpers Optional Gain: 250-500-1000-2000 with new CT-STG V2 module
Offset	Zero adjustment by potentiometer or <u>optional</u> Auto-zero function (which is not lost by power-off), offset range up to 80% of full scale.

CT-TH-K-ISO:

Sensor:	thermo-couple, type K (with cold junction compensation)
Temperature measuring range:	-50°C to +1000°C (other on request) with galvanic isolation

CT-PT100:

Sensor:	resistance temperature detectors (RTDs) with resistance of 100 ohm
Temperature measuring range:	-100°C to +500°C

CT-VOLT:

High-level inputs:	+/- 5 Volt or +/- 10 Volt (other ranges on request)
--------------------	---

CT-ICP:

Sensor:	For ICP® sensor inputs, Current exc. 4mA fixed Signal gain x 2, 4, 8, 16, 32 - Signal bandwidth 3 Hz up to 1500Hz (depended of transmitter)
---------	--

CT-POT:

Sensor:	Potentiometer Sensor >350 Ohms to 10kOhm
Excitation:	4 VDC (fixed)

System Parameters:

Channels:	16
Resolution:	12 bit A/D converter with anti aliasing filter, simultaneous sampling of all channels
Line-of-sight distance:	5-100m (depends of application and bit rate)
Powering:	Li Ion Accumulator 7.2V, 4000mA, capacity for 12 hours.
Power consumption:	400 mA using 16x STG full bridge sensors 350 Ohms
Analog signal bandwidth:	See table
Transmission:	Digital PCM Miller format - FSK
Transmission Power:	10mW!
Weight:	2.5 kg without cables
Operating temperature:	- 20 ... +70°C
Housing:	Aluminum anodized, waterproofed (IP65)
Humidity:	20 ... 80% no condensing
Vibration:	5g Mil Standard 810C, Curve C
Static acceleration:	100g in all directions
Shock:	200g in all directions

Technical specifications are subject to change without notice!

CT-DEC16 Receiver unit for max 16 Channels output via 37 pol. Sub D

Front side view

Female 37 pole Sub-D for analog signal output, CH 1 to 16

Rear side view

Auto Zero LED
Bright on, if analog output is over 60mV (Opt. AZ)

Out of function!

Power Switch

Transmission error LED
Fuse of powering defect LED

7-pole female TUCHEL connector for power supply input (10–30V DC)

PCM out for IP-LAN-Interface (Opt.)

AZ 1-8 9-16

Level

HF –Field strength display

SMA antenna connector with active LED of antenna (diversity)

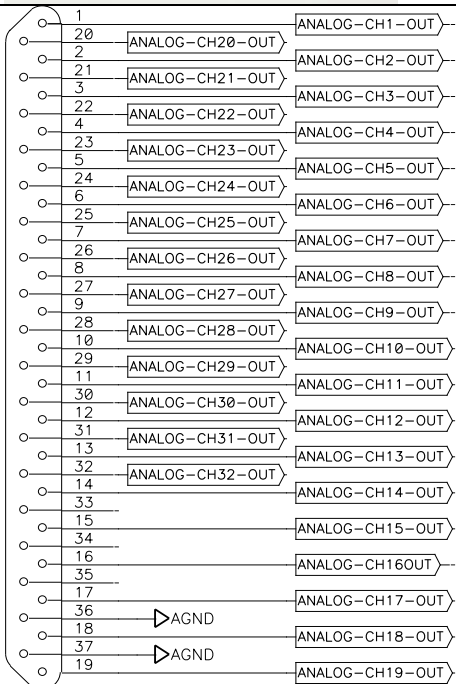

Plug-side

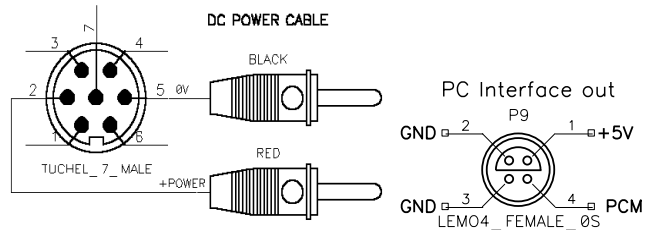

Optional BNC16 Box. Connect on 37pol Sub-D

CT16- -DEC16 System Parameters:

Channel:	16x +/-5V (+/-10V Option) analog outputs via Sub-D male socket
Resolution:	12 bit D/A converter, with smoothing filter
Dynamic:	72dB
Power supply input:	10-30 VDC, power consumption 10 Watt
Current consumption:	300mA at 10V, 100mA at 30V
Transmission:	Digital PCM Miller Format – FSK, diversity receiver
Dimensions:	205 x 105 x 65mm
Weight:	1.25 kg without cables and antenna
Overall system accuracy between encoder input and decoder output:	+/-0.25% without sensor influences
Environmental	
Operating:	-20 ... +70°C
Humidity:	20 ... 80% not condensing
Vibration:	5g Mil Standard 810C, Curve C
Static acceleration:	10g in all directions
Shock:	100g in all directions

Functions:
16 Channel CT16-Rotate ENC (encoder/transmitter)

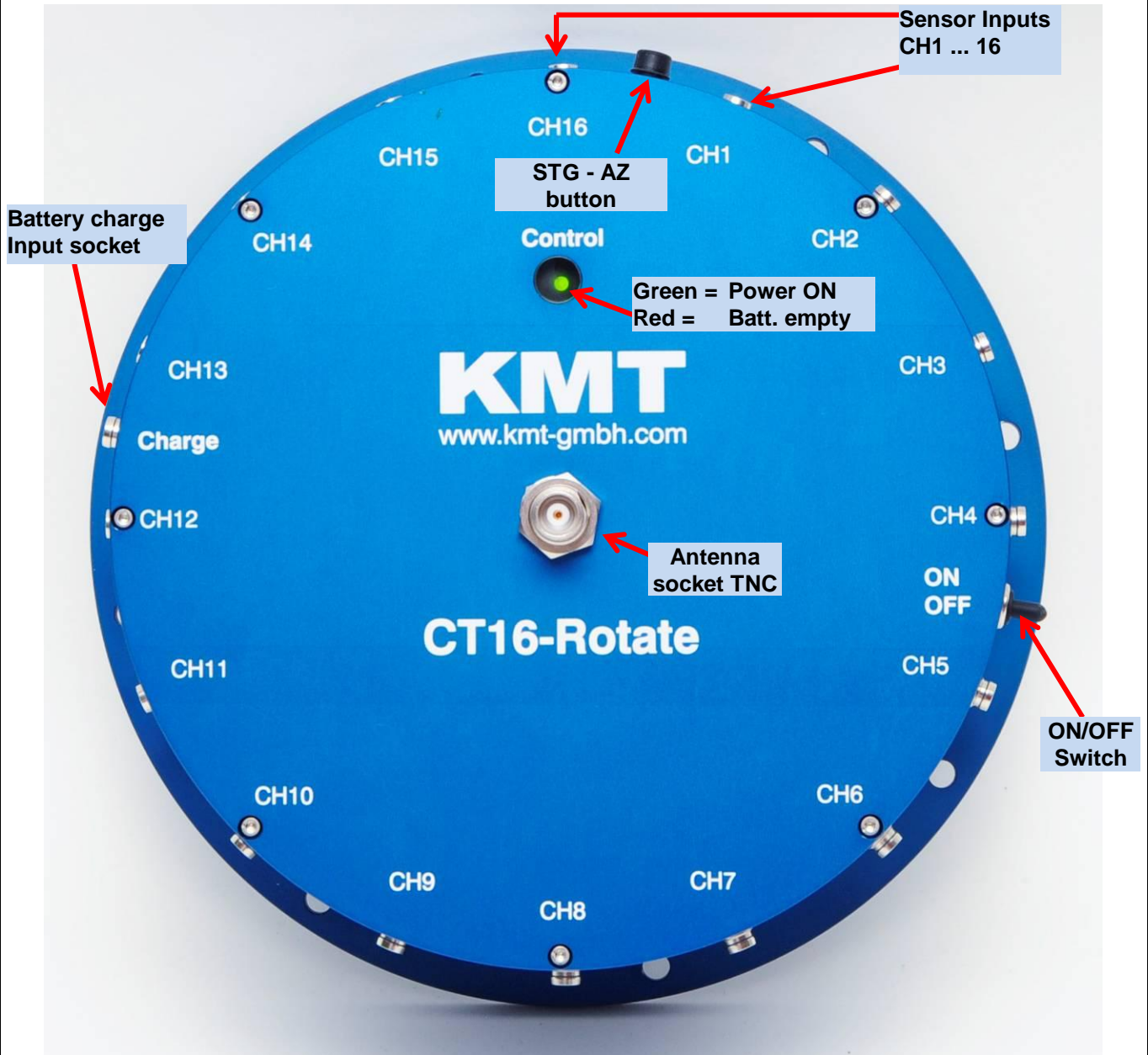

Untwist to open the housing with hexagon screw driver 2mm

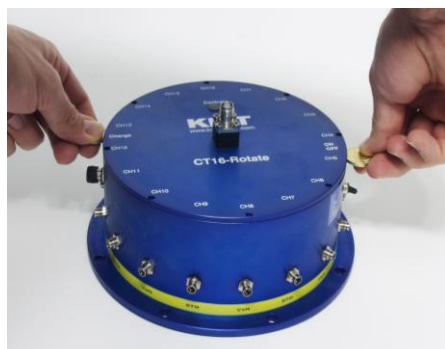

To lift the cover, use the slot!

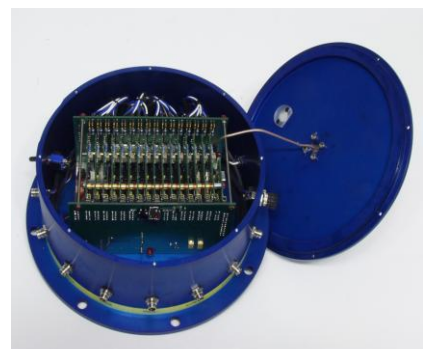

Take care with the O-ring seal, it is lubricated with silicone grease!

Connection, STG bridge configuration: CT16-Rotate ENC (encoder)



Black = IN -
White = IN +
Brown = EXC +
Blue = EXC -



Sensor socket

CT-STG V1 module

Type: Strain gage >350 Ohms
Excitation: 4 VDC (fixed)
Gain: 200 or 1000

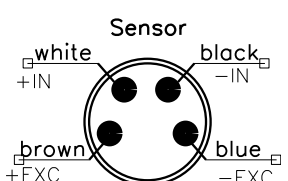

Plug at CT16-Rotate ENC

Sensor modules

CH: 1-2-3-4-5-6-7-8-9-10-11-12-13-14-15-16

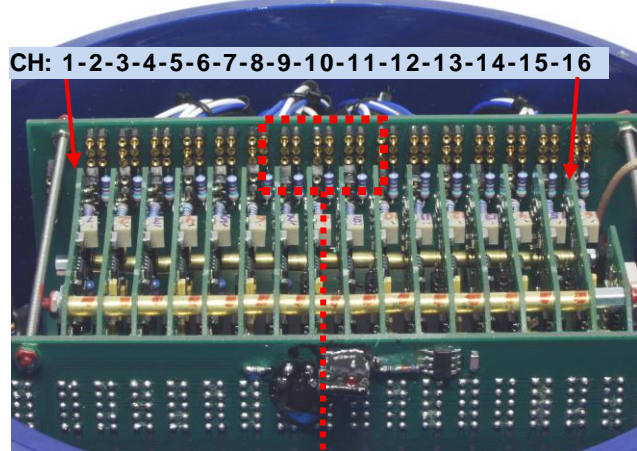

Plug bridge configuration at STG e.g.:

Full Bridge	Full Bridge	Half Bridge	Quarter Bridge
-------------	-------------	-------------	----------------

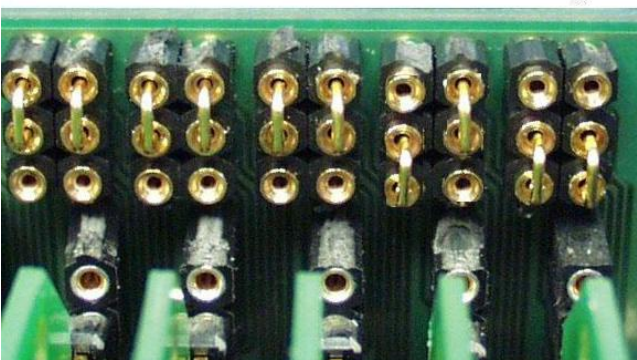

Offset Potentiometer

Gain Gain 1000 *factory setting*

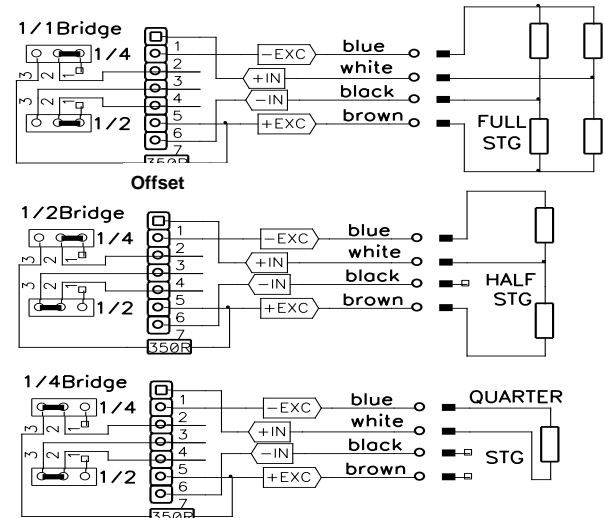
Offset calibration and Gain setting:

Offset potentiometers

Gain 200 or 1000 by solder bridge

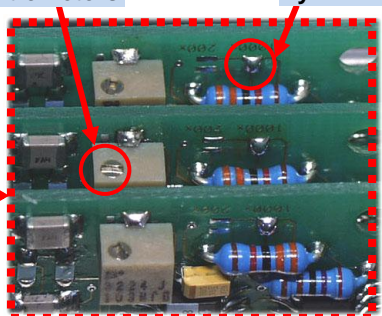

Auto Zero calibration Optional!

Connection, STG bridge configuration: CT16-Rotate ENC (encoder)



Sensor cable

Black = IN -
White = IN +
Brown = EXC +
Blue = EXC -



Sensor socket

CT-STG-V2 module

Type: Strain gage >350 Ohms
 Excitation: 4 VDC (fixed)
 Gain: 250-500-1000-2000 or
 on request 1000-2000-4000-8000

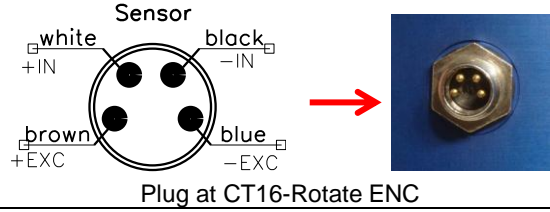

Sensor modules

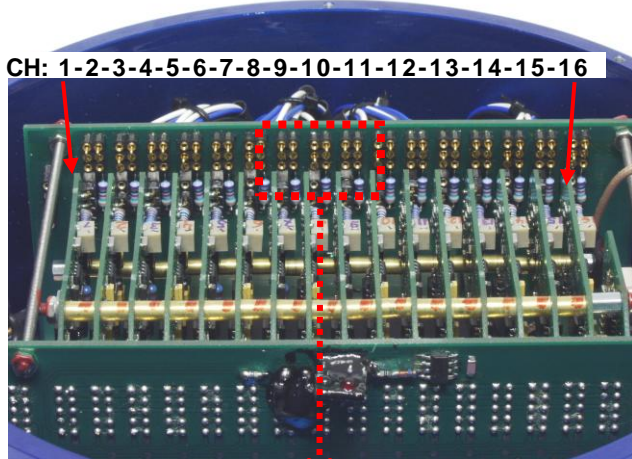

Plug bridge configuration at STG e.g.:

Full Bridge
Full Bridge
Half Bridge
Quarter Bridge

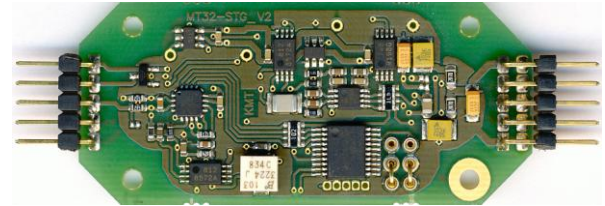

Offset Potentiometer

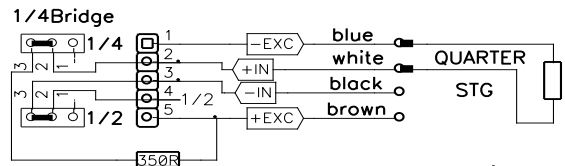
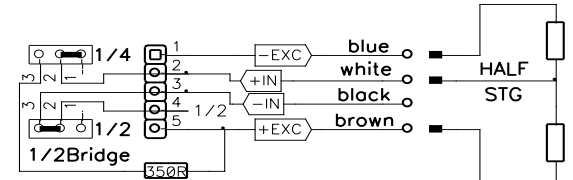
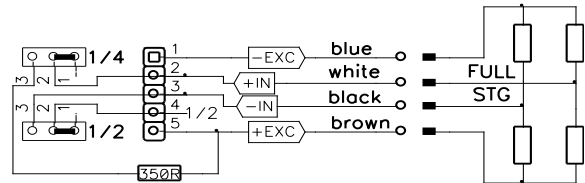
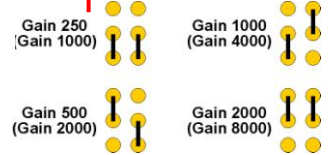

Offset calibration:

Offset potentiometer

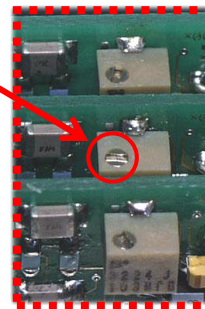

Auto Zero calibration Optional!

Connection POT:

POT module

Type: Potentiometer >350 Ohms
Excitation: 4 VDC (fixed)

Attention:

The POT modules must be configured as a Half Bridge Unit.

Don't change offset and gain!!

Half Bridge

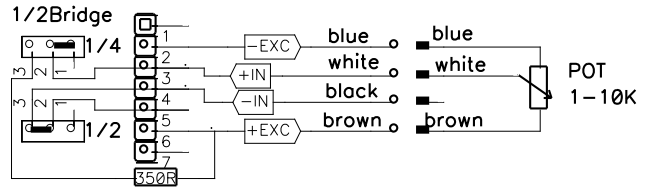

Connection Volt

Volt module

Type: Volt
Range: +/-5 or +/-10V

Attentions:

At Volt modules must plug the plug bridge on Half Bridge Unit.

Don't change offset!!

Half Bridge

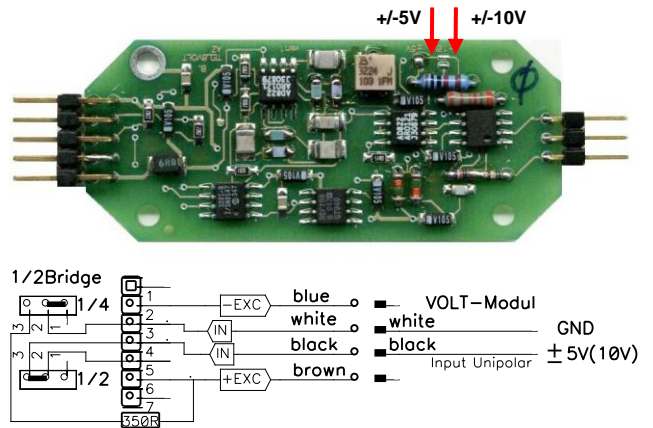

Connection ICP

ICP module

Type: ICP
Gain: 2x, 4x, 8x, 16x or 32x
Constant current: 4 mA

Attentions:

At Volt modules must plug the plug bridge on Half Bridge Unit.

Half Bridge

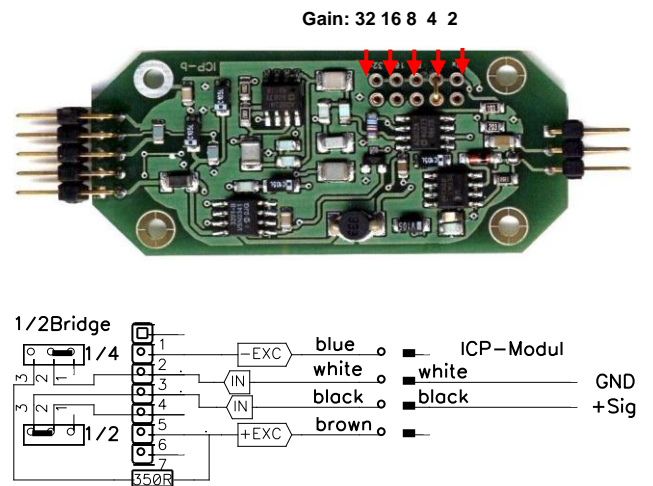

Connection CT-Pt100 module (RTD's)

CT-Pt100

Type: RTD 100 ohm
 Range: -100 to 500°C
 Accuracy +/- 0.25%

Attentions:

At **Thermo couple** must plug the plug bridge on **Half Bridge Unit**.

Half Bridge

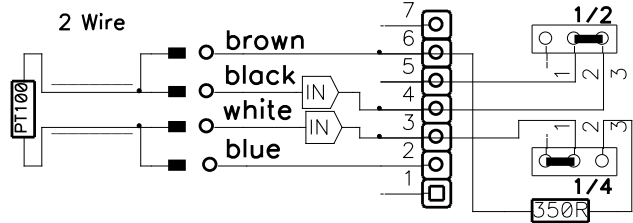

Temperature [°C]	Output [V]	Temperature [°C]	Output [V]	Temperature [°C]	Output [V]
-100	-0,997	150	1,500	400	4,004
-50	-0,497	200	2,001	450	4,498
0	0,001	250	2,501	500	4,999
50	0,499	300	3,001		
100	1,000	350	3,501		

Connection Th K-ISO (with galvanic isolation!)

Thermo couple

Type: K
 Range: -50°C – 1000°C
 Bandwidth: 0-20Hz
 Accuracy +/-1%

Galvanic isolated!

Attentions:

At **Thermo couple** must plug the plug bridge on **Half Bridge Unit**.

Don't change offset!!

Half Bridge

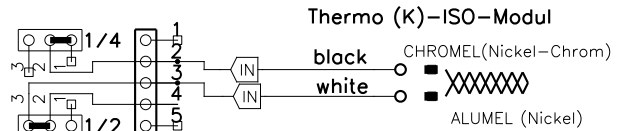
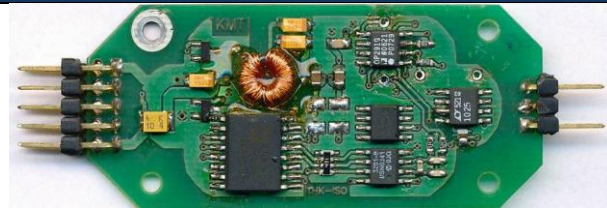

Temperature [°C]	Output [V]	Temperature [°C]	Output [V]	Temperature [°C]	Output [V]	Temperature [°C]	Output [V]
-50	-0.220	250	1.236	550	2.754	850	4.262
0	0.013	300	1.482	600	3.010	900	4.506
50	0.254	350	1.734	650	3.266	950	4.746
100	0.504	400	1.990	700	3.519	1000	4.980
150	0.752	450	2.242	750	3.700		
200	0.992	500	2.498	800	4.015		

Li Ion Re-Chargeable Battery with Charger Unit for CT16-Rotate

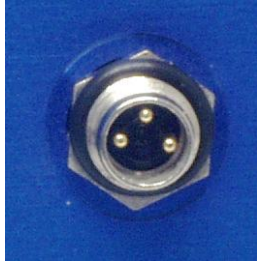
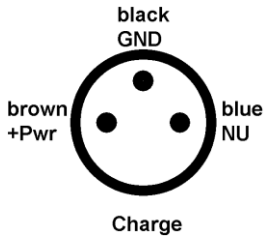

Plug at CT16-Rotate ENC



Battery charger CT16-Rotate

1. Plug the 3- pole socket (charger) in to the CT16-Rotate encoder.
2. Plug banana plugs on to a battery or AC/DC power supply with a voltage range of 10-30V DC.
3. If charging not begins, press for 1 second the switch to begin charging. The battery will now charge. Charge time 8 hours.

Attention:

Li Ion battery (7.2V, 4000mA) has a capacity for 12 hours. If the red LED indicator (Control) on the CT16-Encoder is ON the battery is 80% discharged and the device will switch off after 20 minutes!

Mounting hole dimensions:

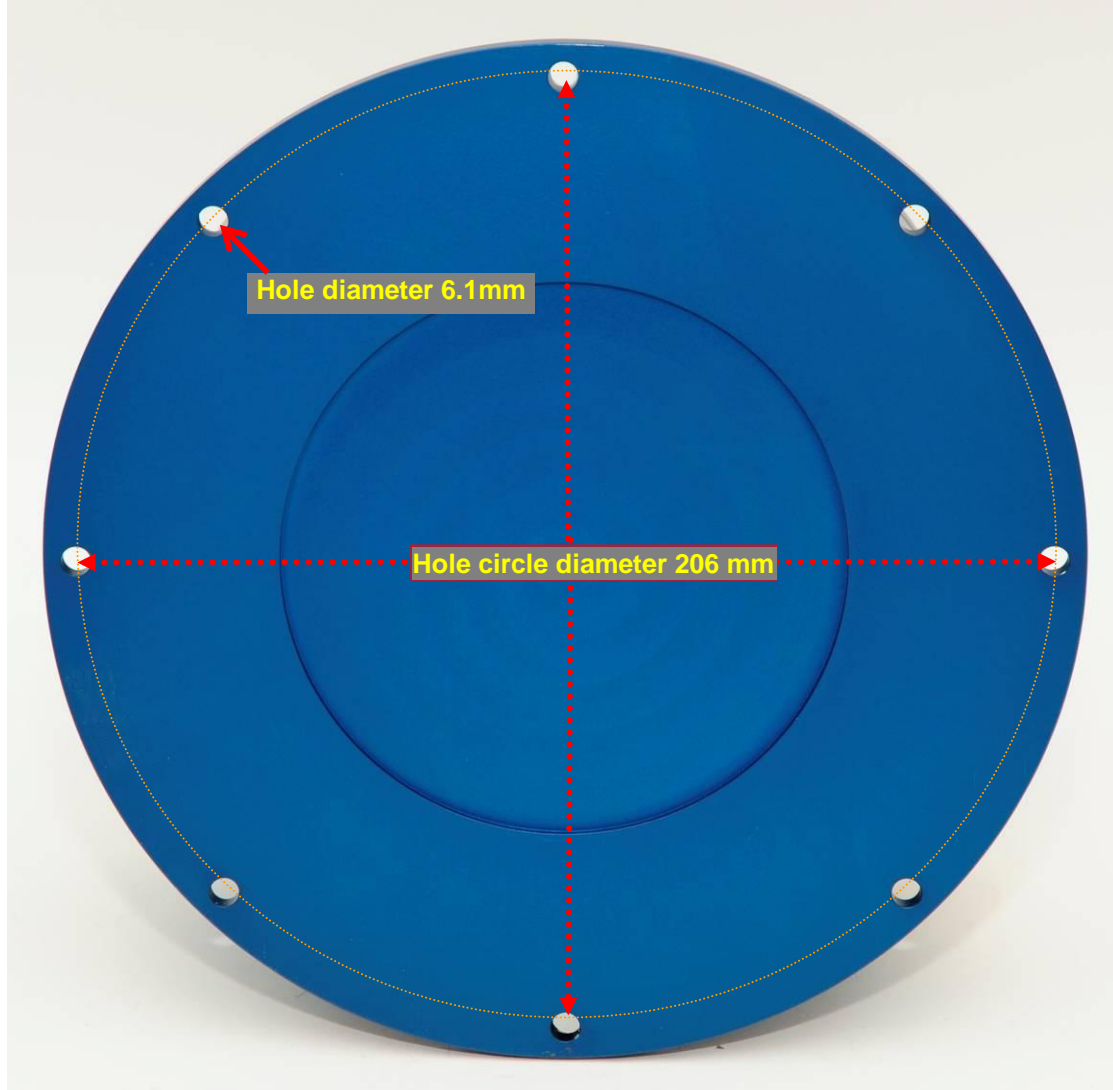

Base plate side

Dimensions:

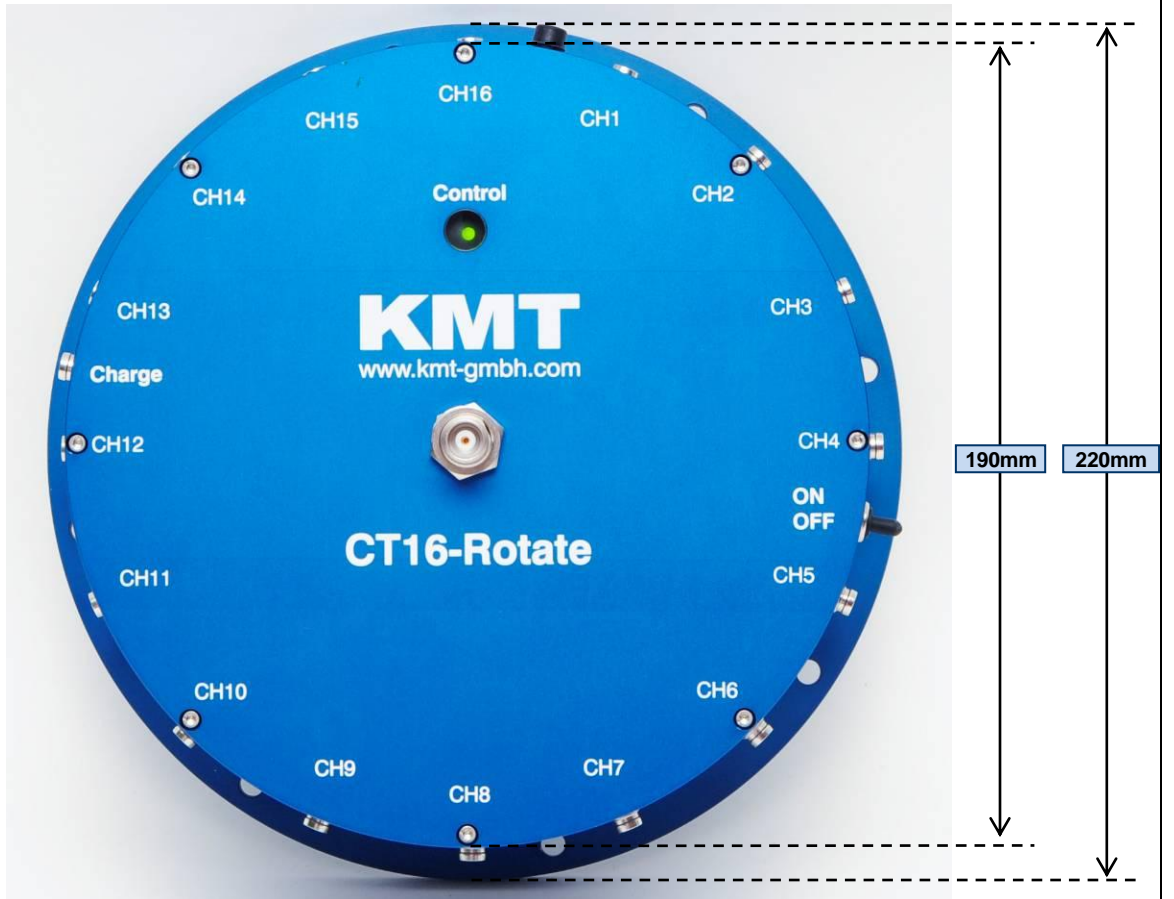

Total weight 2.5 kg