

MC16/64

Data acquisition notebook

„From sensor to result“



- 16 channels sensor inputs (up to 64)
- Total sampling rate 80 kHz, simultaneous S+H, 12 bit resolution
- Acquisition of physical quantities like distances, velocities, accelerations, vibrations, distortions, shocks, revolutions, temperatures, torsion's etc.
- Channel separate signal conditioning with different sample rates
- Parallel online display and data storage to HDD
- Telemetry option
- Extensive software support for signal analysis

The design follows our philosophy, compact and robust but still very flexible to fulfill almost all requirements. The basic version consists of 16 channels for various signal conditioning cards (available for all common sensors). An extension up to 64 channels is possible.

The signals from the different sensors will convert into an analog voltage with a range of $\pm 5V$. Each overload is captured and displayed by hardware to support corrections directly on site. The offset e.g. from STG or LVDT sensors can easily be compensated by pressing the „Auto Zero“ button. The individual definable channel bandwidths as well as integrated filters with various cut off frequencies enables the optimal use of the total sample rate and eliminates the „Aliasing“ effect. The total sample rate of 80, 40, 20, 10, 5 or 2.5kSample/s can be freely distributed to the different channels down to a bandwidth of 40Hz. To do this, the user can choose between 16 self-defined setups. The simultaneous sampling of all channels guarantees an exact time correlation during signal analysis.

The rugged notebook CF-29 from Panasonic is equipped with Pentium M 738 1.4GHz, 512MB, 60GB Harddisk and high resolution TFT display and can be easily separated from the measure unit. This is very useful during long-time data acquisition for intermediate evaluations of signals without disconnecting the measure unit from the investigated object.

For data storage and online-displaying the data, we use our μ Lab software and for data analysis μ Graph.

In combination with our appreciated DAT recorders and telemetry systems the MC16/64 advances to a high end measuring station, prepared for most applications, also under very rough conditions. The minimized design allows mobile applications and does almost not require any space on site. The data transfer (PCM coded information) can be done via BNC cable or via telemetry if necessary (long distances or if a cable transfer is not possible). The transmitter is directly connected to the measuring station and does not need an external power supply. The received signal is without errors thanks to the diversity receiving system with two antennas. Via a PCMCIA interface the data will transfer into the notebook.

For applications where shock or vibration requirements are too high, we recommend our well-known DAT recorders for off-line transfer to the notebook or direct transmission via telemetry if required.

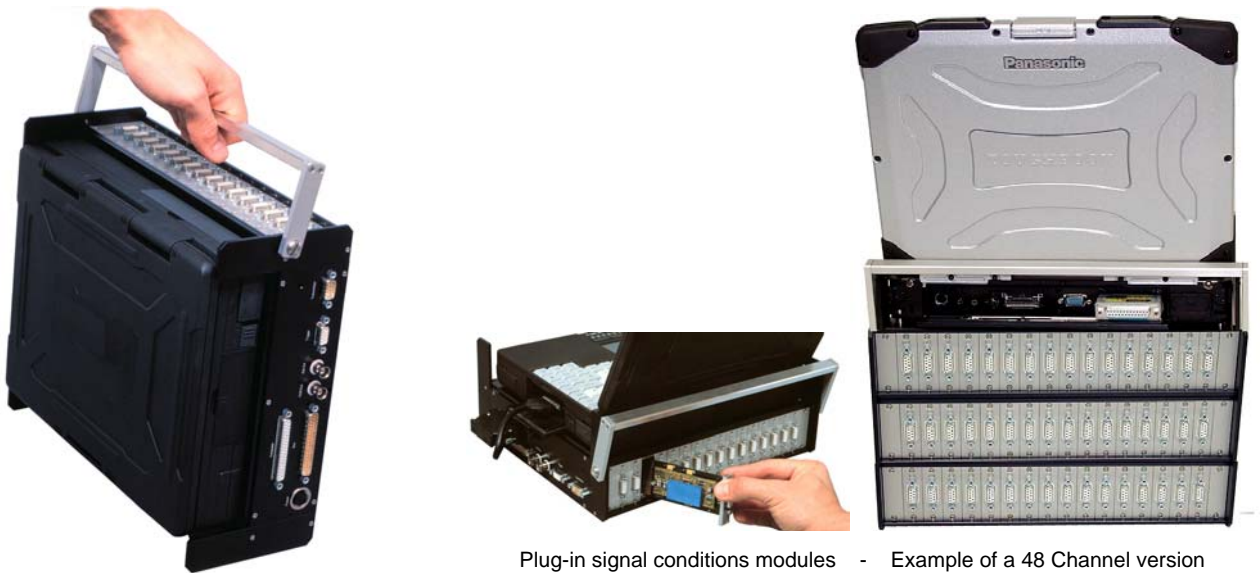

Plug-in signal conditions modules - Example of a 48 Channel version

Block diagram

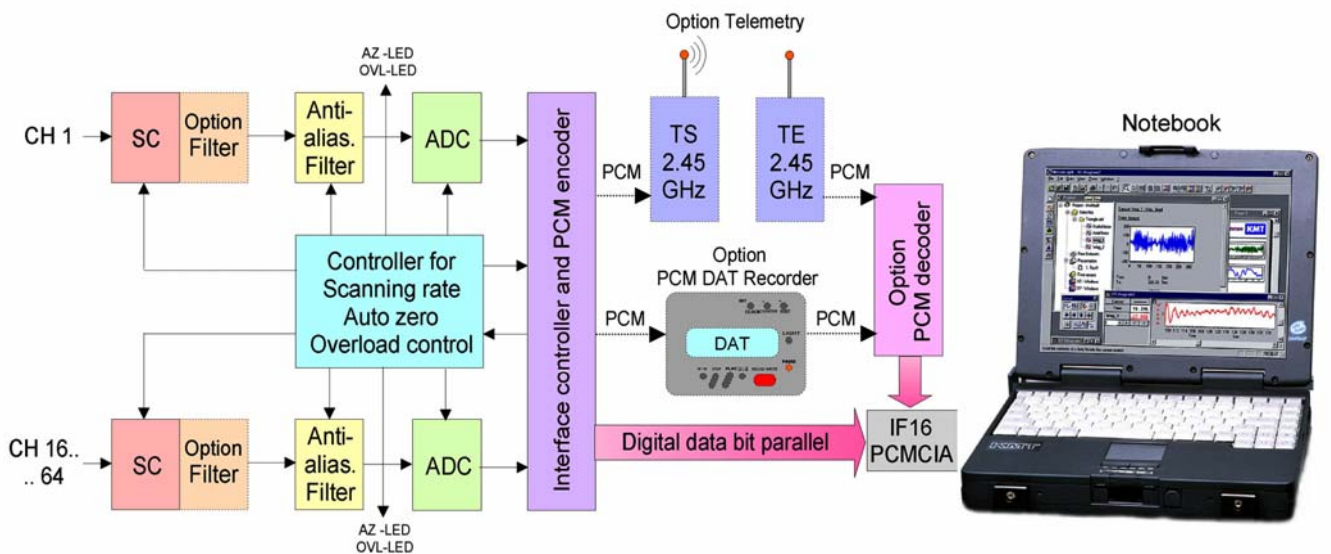

Specification

System:			
No. of channels:	16 in the base unit, expandable to 32, 48, 64		
Auto zero:	automatically over the full measuring range		
Sampling:	simultaneous		
Total sample rate:	80, 40, 20, 10, 5, 2.5kSamples/s		
Channel sample rate:	total sample rate divided by 2, 4, 8, 16, ... down to 156,25 Samples per second (added sample rates of all channels is equal to the total sample rate) 16 predefined setups are available (different for 16, 32, 48 and 64 channel version)		
Resolution:	12Bit, 72dB dynamic range		
Software:	µ-Lab and µ-Graph		
Notebook	Rugged notebook "Panasonic CF-29 Toughbook" (more details see website from Panasonic) Pentium M 738 1.4GHz, 512MB, 60GB HDD Processor: Intel Pentium M 738 1.4 GHz Cache Memory: 2MB - L2 Cache RAM: 512MB / MAX 1536MB Hard Drive: 60GB Display: 1024 x 768 (XGA), TFT Active Matrix Color LCD with Touchscreen Graphics Controller: Intel® 855GME graphic controller Audio Output: Sound Card - Telecom: 56 Fax / modem - 56Kbs Networking: Internal 10/100 / Intel® Pro Wireless 2915ABG WLAN Input Device: Keyboard, Touchpad - Battery: Lithium Ion Operating System: Microsoft Windows XP Professional		
Interfaces:	PCM (Miller) output with clock, transmitter output including power supply, single and multiple analog signal output (±5V), 37 pin connector to IF16-Card (PCMCIA or Desktop) for data transmission		
Power supply:	10-18V DC (optional 18-30V)		
Dimensions:	16 channel base unit: 320 x 260 x 130mm 16 channel extension 320 x 260 x 60mm		
Signal conditioning for:			
To measure:	Module	Description	Characteristics
Force, pressure, strain, torsion, material stress	STG	Strain gauges	<ul style="list-style-type: none"> • Full, half, quarter bridges in 2- and 3-wire technique (120Ω, 350Ω, 1kΩ) • Setable gain (10, 100, 1000) • Setable bridge supply (4V, 8V) • Auto zero • Additive 5kHz fixed filter (2pol. Butterworth)
distance	LVDT	Inductive distance sensor	<ul style="list-style-type: none"> • Setable gain (1, 2, 5, 10) • Sensor supply 5kHz, 2.5V • Auto zero
Frequency, speed by pulse frequency	F/V	Frequency-to-voltage converter	<ul style="list-style-type: none"> • Setable maximum frequency (500Hz, 2.5kHz, 10kHz) • Minimum frequency 40Hz • Signal amplitude 0.3-10V • Square, sine and triangle wave forms • 10Hz output filter (2pol. Butterworth)
Acceleration, oscillation, vibrations	ACC	Acceleration sensor based on STG	<ul style="list-style-type: none"> • all common sensors
	CAP	Capacitance accelerometer	
	ICP	Piezoelectric accelerometer	
Temperature	THERMO	Thermo wires Type J, K (T)	<ul style="list-style-type: none"> • Measuring range from -20°C up to +500°C • Gain 10mV/°C • Internal cold junction compensation • Optional galvanic isolation with integrated ISO module
galvanic isolated voltage	ISO	Isolation amplifier	<ul style="list-style-type: none"> • Additive isolated sensor excitation • Optional 4Hz fixed filter (4pol. Butterworth)
Current	CUR	Current-to-voltage converter	<ul style="list-style-type: none"> • Input current 0-20mA • Input impedance 125Ω • Bridge excitation 12V
Voltage	VOLT	No signal conditioning	<ul style="list-style-type: none"> • 1:1 buffer amplifier, Input +/-5V (opt. +/-10V)
	FILTER	Optional filter for all modules	<ul style="list-style-type: none"> • 8th order elliptical or linear phase frequency response, more than 2000 cut off frequencies from 10Hz to 7,5kHz available (reciprocal scaling)

μ -Lab and μ -Graph

DATA ACQUISITION AND ANALYSIS WITH 32-BIT-POWER

For the first time, KMT & CAESAR is able to present a software packet specially designed for comfortable data acquisition and analysis under Windows-XP - **μ -Edition**. The program modules **μ -Lab** and **μ -Graph** make full use of the 32-bit qualities of these operating systems and thus combine a performance previously unknown on a PC extreme ease of use.

μ -Lab enables data from an unlimited number of digital and analog channels to be acquired, processed online, displayed and output again. As far as the hardware is concerned, data acquisition and output cards from a large range of well known manufacturers and, of course, the MOPS and PCM-Systems are supported. Sample rates from under 1 Hz to more than 100 kHz (continuous) or 500 kHz (Burst) are possible, depending on the hardware used. The acquired data can be distributed among an unlimited number of files. Even the basic μ -Lab version contains a wide range of trigger functions and action modules for limit surveillance, time control, data reduction and various smoothing algorithms. Each channel can be calibrated either linearly or non-linearly. By means of the online-graphic, an unlimited number of graphical objects can be displayed simultaneously: e.g. xt-digram (incl. scroll and scope mode), xy-digram, bar diagram, numerical display or text switch. The properties - e.g. axis scaling, color, text fonts - can be defined separately for each individual object. The functionality of the basic version can be extended, if desired, with the help of additional modules, e.g. for online computation, DIN and Rainflow classification (bin analysis), frequency analysis and signal generation.

μ -Graph is a flexible, graphical analysis program for all kinds of measured data. It combines the following functions: quick-look, interactive processing, data management, presentation graphic, statistic, formula generator and, optionally, frequency analysis and bin analysis in a user interface which is particularly intuitive and easy to use. The analysis is carried out simply by dragging (Drag & Drop) the marked datasets onto the corresponding button in a toolbar (e.g. print or FFT). μ -Graph is, of course, fully compatible to the REMUS-data format. A special highlight is the incredibly fast quick-look function, which enables the largest datasets to be displayed in a fraction of a second: simply click on the dataset name and even several megabytes of measured data appear at once on the screen without any noticeable delay together with the most important statistical parameters. The quick-look has even more to offer: with the help of the mouse, any particular dataset can be marked and either printed or displayed in the interactive cursor mode. Here a wide range of functions are available, e.g. line, crosshair and difference cursor, zooming, scrolling, marking and labelling. While scrolling through long sequences of data, bookmarks can be set so that points of particular interest can easily be found again. Each dataset can be displayed in an xt-diagram, xy-diagram, bar diagram or table with manual or automatic scaling. The flexible presentation graphic in μ -Graph enables records and reports to be freely defined. Together with standard functions for drawing and labelling, the OLE interface makes it possible to include objects from other Windows programs (e.g. Excel or Word). A report that has been designed once can be stored as a template and used again when required simply by clicking a button.

