

CT4/8-Wheel

User Manual



- STG offset via potentiometer or optional Auto Zero calibration
- 12 bit ADC resolution, simultaneous sampling of all channels
- Signal bandwidth:
4 x 0-190 Hz, 8 x 95 Hz with 40kbit Tx
4 x 0-1500 Hz, 8 x 750 Hz with 320kbit Tx
4 x 0-3000 Hz, 8 x 1500 Hz with 640kbit Tx
4 x 0-6000 Hz, 8 x 3000 Hz with 1280kbit Tx
- Water protected housing (IP65)
- Output analog (+/- 5V) and digital for PC interface at the receiver side
- Universal mounting adapter for fast and exactly montage on the wheel
- 4x different carrier frequencies (only with 40kbit Tx) enable measurements at four Wheels at one car or truck
- 320...1280kbit with diversity receiver!
- Accumulator powered (up to 10h)

General functions:



Picture shows a CT8-Wheel telemetry system with standard accessories and diversity option!

CT4/8-Wheel is an telemetry system designed for easy mounting onto rotating Wheels to provide non-contact transmission of measured parameters such as pressure, force, temperature, acceleration and voltage.

Sensors inputs are connected via screw on, waterproof connectors. Measured values are prepared in analog format, digitized and transmitted via radio frequencies. Four different carrier frequencies are provided, this allows up to four systems (e.g. for four wheels) to operate in parallel. The complete transmitter assembly is waterproofed to IP65 specifications.

The following sensors can be connected to the system: (STG) Strain gages sensors in full-, half- and quarter-bridge configuration (350 ohm or greater), Type K Thermocouples -50 to 1000°C, ICP and capacitive sensors. Voltage inputs of +/-5V and +/-10V are available.

The measured values are processed and output as +/-5V analog signals at the BNC sockets (optional digital output for special PCM interface into a PC) on the stationary receiver located in a vehicle or helicopter cabin.

Resolution of 12 bits is standard; this enables an amplitude dynamic of 72 dB. The analog signal bandwidth is 0-95 Hz (-3dB) when configured as an eight channel unit, other bandwidth on request! The measurement accuracy is +/-0.25 % (without sensor). The CT4/8-Wheel is suited for operation at ambient temperatures of -20 to +70°C. The transmission distance between transmitter and receiving antenna is of the order of 10-20m with 40kbit depend of application!



Transmitter Device (Encoder)



with internal Tx-antenna only for 40kbit



with internal Tx antenna recommend >320.....1280kbit

CT8-Wheel

CT-STG V1:

Sensor: strain gage, ≥ 350 Ohms
 Bridge completion: full, half and quarter-bridge (optional)
 Excitation: 4 VDC (fixed), short-circuit protection up to 20mA
 Gain: 200 or 1000 - selectable by solder jumpers
Optional Gain: 250-500-1000-2000 with new CT-STG V2 module
 Offset: Zero adjustment by potentiometer or optional Auto-zero function (which is not lost by power-off), offset range up to 80% of full scale.

CT-TH-K-ISO:

Sensor: thermo-couple, type K (with cold junction compensation)
 Temperature measuring range: -50°C to +1000°C (other on request) **with galvanic isolation**

CT-PT100:

Sensor: resistance temperature detectors (RTDs) with resistance of 100 ohm
 Temperature measuring range: -100°C to +500°C

CT-VOLT:

High-level inputs: +/- 5 Volt or +/- 10 Volt (other ranges on request)

CT-ICP:

Sensor: For ICP® sensor inputs, Current exc. 1, 4, and 10mA
 Signal gain x 2, 4, 8, 16, 32 - Signal bandwidth 3 Hz up to 3000Hz (8 CH)
(depended of transmitter kbit)

CT-POT:

Sensor: Potentiometer Sensor >350 Ohms to 10kOhm
 Excitation: 4 VDC (fixed)

System Parameters:

Channels: 4 or 8
 Resolution: 12 bit A/D converter with anti aliasing filter, simultaneous sampling of all channels
 Line-of-sight distance: 20 m with 10mW transmitting power (433MHz Band, FSK modulation)
 Powering: Li Ion Accumulator 7.2V, 2200mA, capacity for 8-10 hours
 Power consumption: 200 mA (at 7,2V) using 8 STG sensors at 350 Ohms with CT-STG-V1

Cut off frequency from anit-aliasing filter (-3dB)		
Scanning rate (red)		
Bit rate	4 Channels	8 Channels
1280 kbit/s	6000 Hz (24615 Hz)	3000 Hz (12800 Hz)
640 kbit/s	3000 Hz (12308 Hz)	1500 Hz (6400 Hz)
320 kbit/s	1500 Hz (6154 Hz)	750 Hz (3200 Hz)
40 kbit/s	190 Hz (770 Hz)	95 Hz (400 Hz)

depending of transmitter!

Analog signal bandwidth:

Dimensions: Diameter 160mm, bottom plate diameter 190mm, height 65mm
 Weight: 1.50 kg without cables
 Transmission: Digital PCM Miller format - FSK
 Transmission Power: 10mW
 Operating temperature: - 20 ... +70°C
 Housing: Water resistant (IP65)
 Humidity: 20 ... 80% no condensing
 Static acceleration: 100g in all directions
 Shock: 200g in all directions

Technical data:
Receiving Unit CT8-Wheel DEC (Decoder)

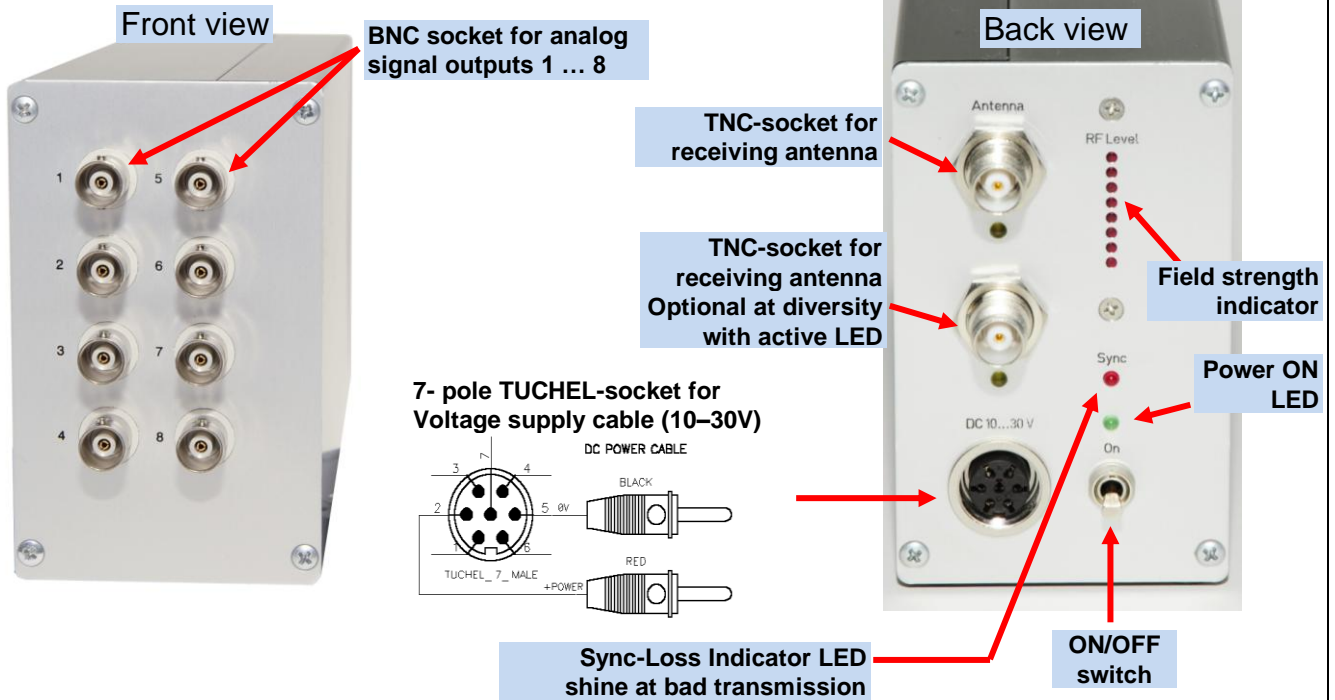

System Parameters:

Channel: 8 analog outputs via (BNC) +/-5V
 Resolution: 12 bit D/A converter, with smoothing filter
 Dynamic: 72dB
 Power supply input: 10-30 VDC
 Current consumption: 300mA at 10V, 100mA at 30V

Cut off frequency from anit-aliasing filter (-3dB)		
Scanning rate (red)		
Bit rate	4 Channels	8 Channels
1280 kbit/s	6000 Hz (24615 Hz)	3000 Hz (12800 Hz)
640 kbit/s	3000 Hz (12308 Hz)	1500 Hz (6400 Hz)
320 kbit/s	1500 Hz (6154 Hz)	750 Hz (3200 Hz)
40 kbit/s	190 Hz (770 Hz)	95 Hz (400 Hz)

Analog signal bandwidth:

Dimensions: 205 x 105 x 65mm
 Weight: 1.00 kg without cables and antenna

Overall system accuracy between encoder input and decoder output: +/-0.25% without sensor influences, with CT-TH-K-ISO only +/-1%

Environmental

Operating: -20 ... +70°C
 Humidity: 20 ... 80% not condensing
 Vibration: 5g Mil Standard 810C, Curve C
 Static acceleration: 10g in all directions
 Shock: 100g in all directions

Technical specifications are subject to change without notice

Functions:
8 Channel CT8-Wheel ENC (encoder/transmitter)

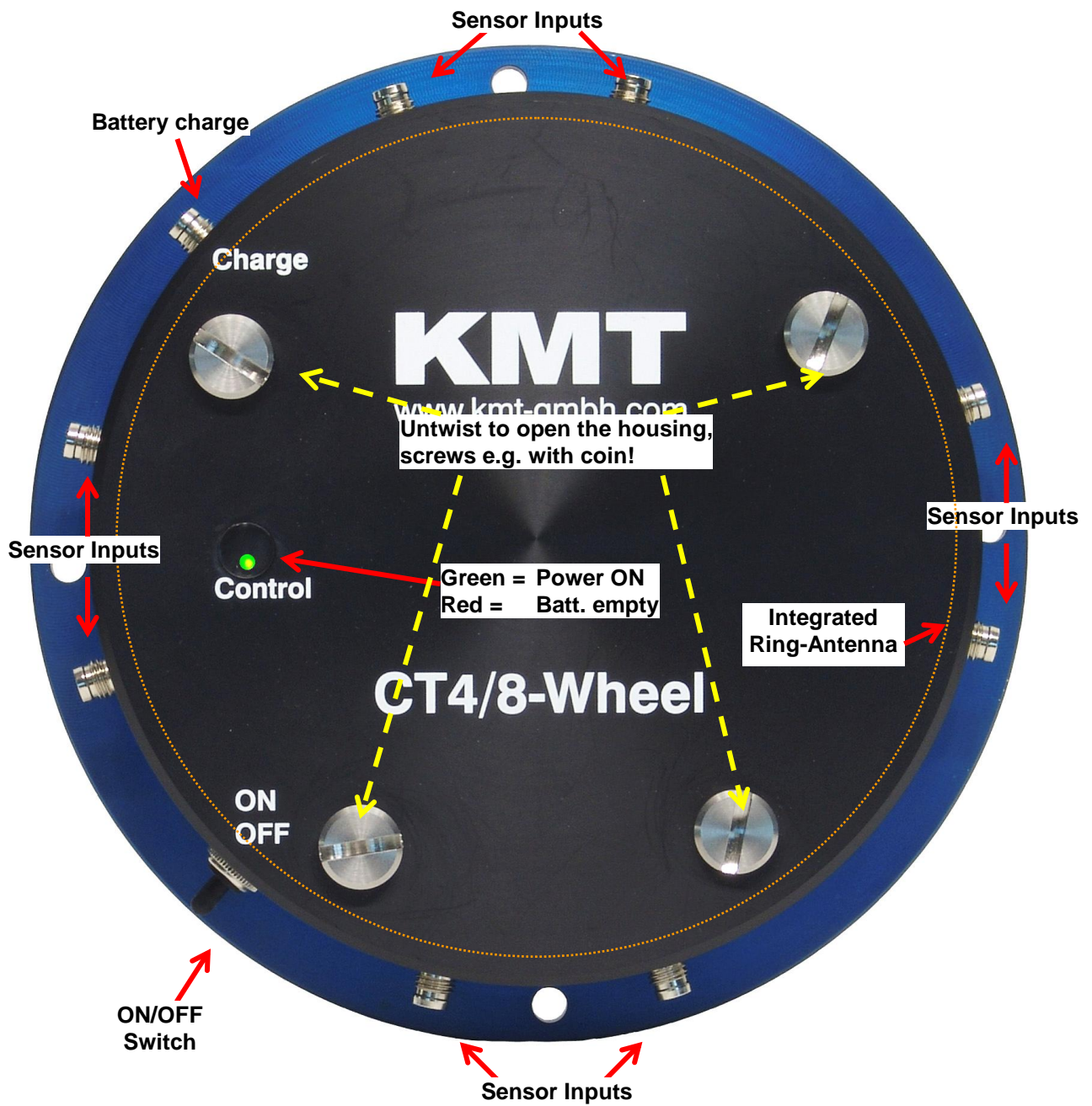

Untwist to open the housing, screws e.g. with coin!



To lift the cover, use the slot!



Take care with the O-ring seal, it is lubricated with silicone grease!

Connection, STG bridge configuration: CT8-Wheel ENC (encoder)



Sensor cable

Black = IN -
White = IN +
Brown = EXC +
Blue = EXC -



Sensor socket

CT-STG-V1 module

Type: Strain gage >350 Ohms
Excitation: 4 VDC (fixed)
Gain: 200 or 1000
Accuracy +/- 0.25%

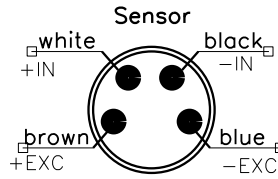

Plug at CT8-Wheel ENC

Sensor modules

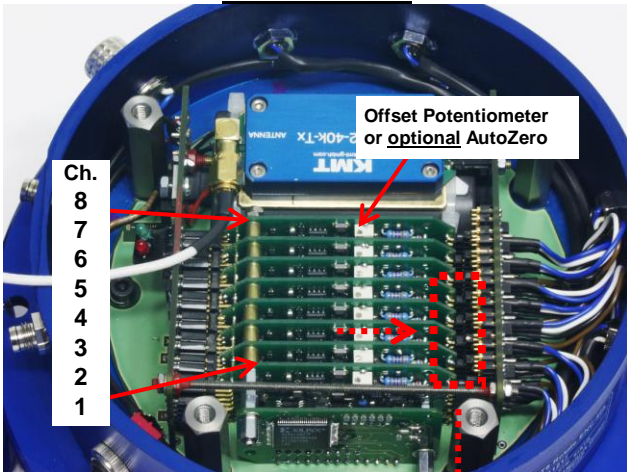

Offset Potentiometer

Gain 200 Gain 1000 - *factory setting!*

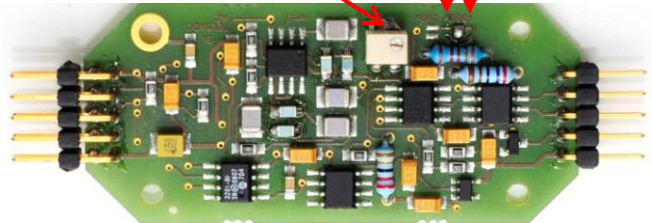

Plug bridge configuration at STG e.g.:

Full Bridge Full Bridge Half Bridge Quarter Bridge

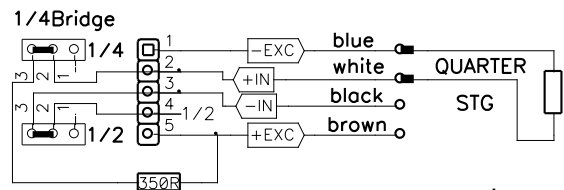
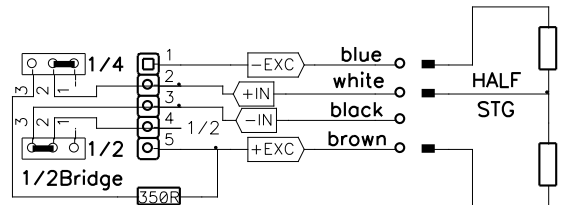
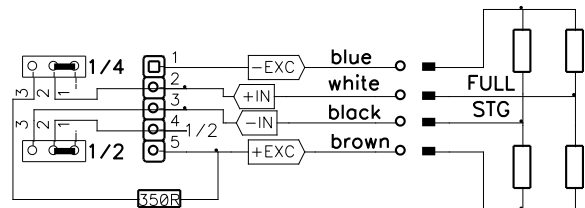
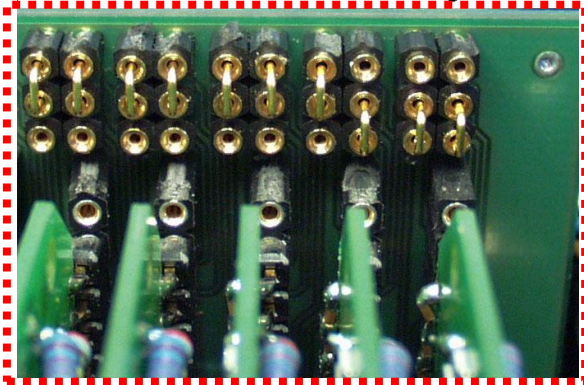

Offset calibration and Gain setting:

Offset potentiometers

Gain 200 or 1000 by solder bridge
(1000=Factory setting)

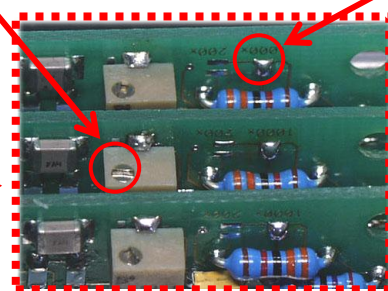

Auto Zero calibration Optional!

Connection, STG bridge configuration: CT8-Wheel ENC (encoder)



Sensor cable

Black = IN -
White = IN +
Brown = EXC +
Blue = EXC -



Sensor socket

CT-STG-V2 module

Type: Strain gage >350 Ohms
Excitation: 4 VDC (fixed)
Gain: 250-500-1000-2000 or on request
1000-2000-4000-8000

Accuracy +/- 0.25%

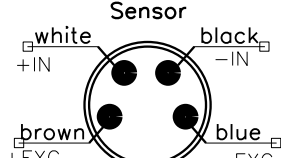
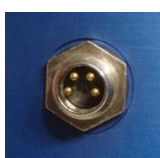
Plug at CT8-Wheel ENC

Sensor modules

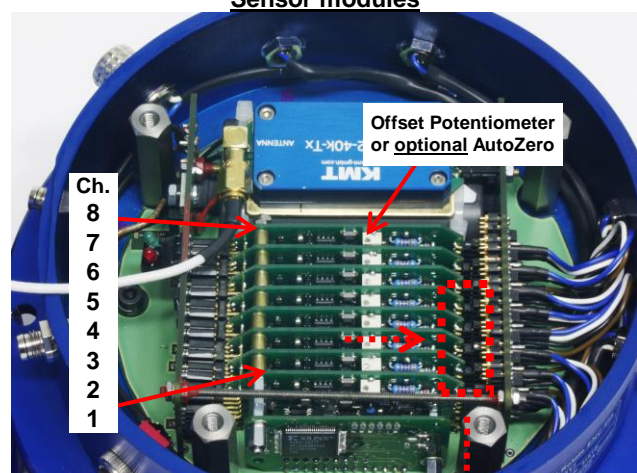

Offset Potentiometer
or optional AutoZero

Ch.
8
7
6
5
4
3
2
1

Plug bridge configuration at STG e.g.:

Full Bridge	Full Bridge	Half Bridge	Quarter Bridge
-------------	-------------	-------------	----------------

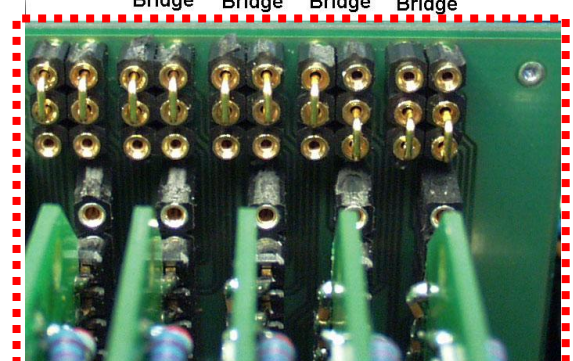

Gain 250
(Gain 1000)



Gain 1000
(Gain 4000)



Gain 500
(Gain 2000)



Gain 2000
(Gain 8000)



Offset Potentiometer

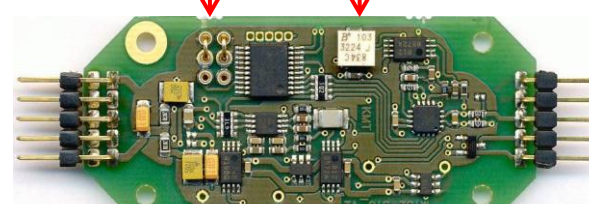

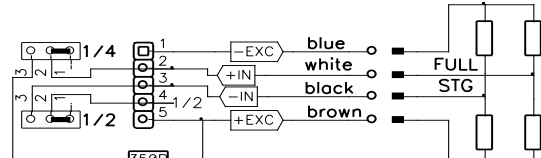

FULL STG

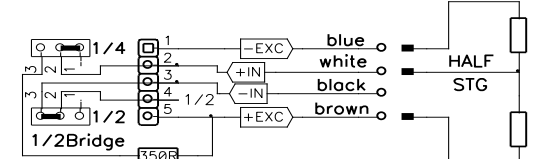

HALF STG

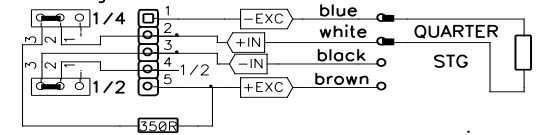

QUARTER STG

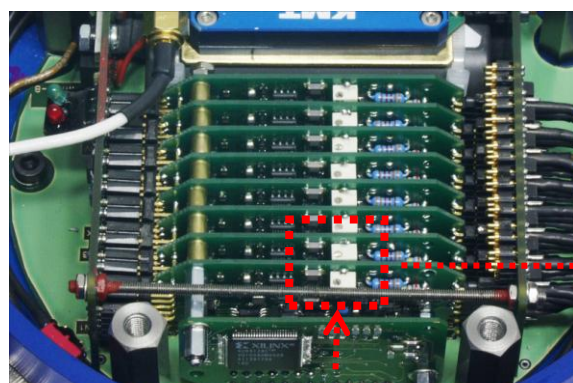

Offset calibration:

Offset potentiometers

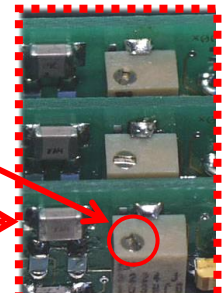

Auto Zero calibration Optional!

Connection POT:

POT module

Type: Potentiometer >350 Ohms
 Excitation: 4 VDC (fixed)
 Accuracy +/- 0.25%

Attention:

The POT modules must be configured as a Half Bridge Unit.

Don't change offset and gain!!

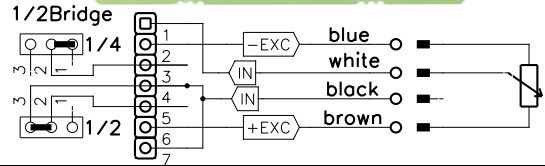
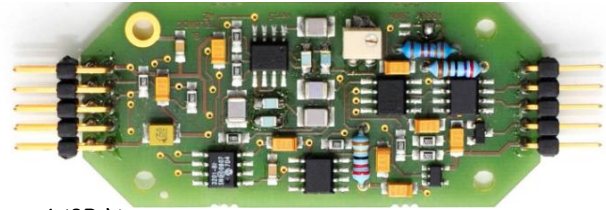

Connection Volt

Volt module

Type: Volt
 Range: +/-5 or +/-10V
 Accuracy +/- 0.25%

Attentions:

At Volt modules must plug the plug bridge on Half Bridge Unit.

Don't change offset!!

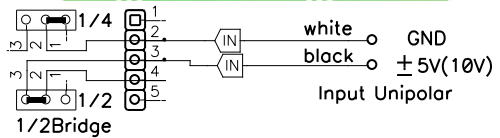
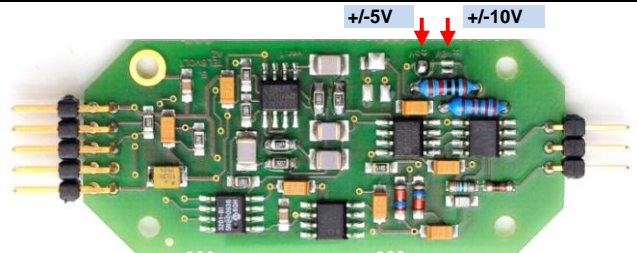

Connection Volt-ISO

Volt module

Type: Volt input with galvanic isolation!
 Range: +/-5 or +/-10V
 Accuracy +/- 0.25%

Attentions:

At Volt modules must plug the plug bridge on Half Bridge Unit.

Don't change offset!!

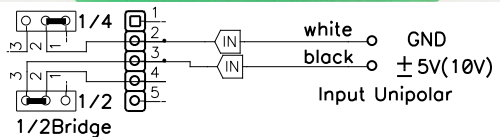

Connection ICP V2

ICP module

Type: ICP
 Gain: 2x, 4x, 8x, 16x or 32x
 Constant current: 4mA
 Accuracy +/- 0.25%

Attentions:

At Volt modules must plug the plug bridge on Half Bridge Unit.

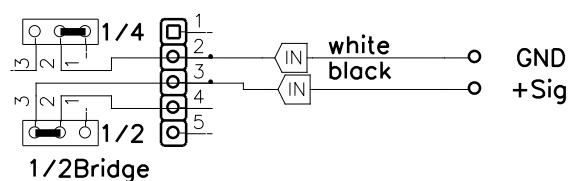
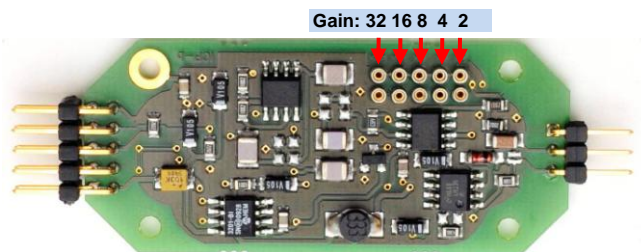

Connection CT-Pt100 module (RTD)

CT-Pt100

Type: RTD 100 ohm
 Range: -100 to 500°C
 Accuracy +/- 0.25%

Attentions:

At **Thermo couple** must plug the plug bridge on **Half Bridge Unit**.

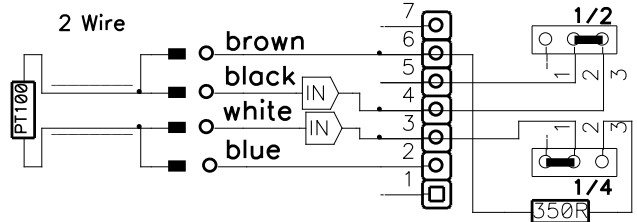

Temperature [°C]	Output [V]	Temperature [°C]	Output [V]	Temperature [°C]	Output [V]
-100	-0,997	150	1,500	400	4,004
-50	-0,497	200	2,001	450	4,498
0	0,001	250	2,501	500	4,999
50	0,499	300	3,001		
100	1,000	350	3,501		

Connection Th K-ISO (with galvanic isolation!)

Thermo couple

Type: K
 Range: -50°C – 1000°C
 Bandwidth: 0-20Hz
 Accuracy +/-1%

Galvanic isolated!

Attentions:

At **Thermo couple** must plug the plug bridge on **Half Bridge Unit**.

Don't change offset!!

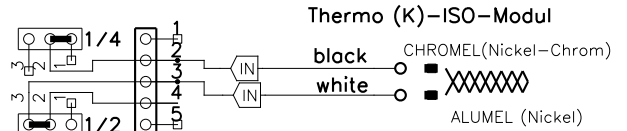

Temperature [°C]	Output [V]	Temperature [°C]	Output [V]	Temperature [°C]	Output [V]	Temperature [°C]	Output [V]
-50	-0.220	250	1.236	550	2.754	850	4.262
0	0.013	300	1.482	600	3.010	900	4.506
50	0.254	350	1.734	650	3.266	950	4.746
100	0.504	400	1.990	700	3.519	1000	4.980
150	0.752	450	2.242	750	3.700		
200	0.992	500	2.498	800	4.015		

Li Ion re-chargeable battery with charger unit for CT8-Wheel

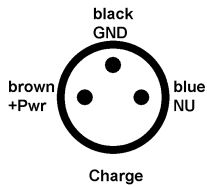

Charge plug at CT8-Wheel ENC



Attention:

Li Ion battery (7.2V, 2200mA) has a capacity for >6-8 hours. If the red LED indicator, on the Transmitter is ON the battery is 80% discharged and the device will switch off after 20-30 minutes!



CT-CHARGER for CT8-Wheel

1. Plug the 3-pole socket (charger) in to the CT8-Wheel encoder.
2. Plug banana plugs on to a battery or AC/DC power supply with a voltage range of 10-30V,
3. Press and hold the switch for 1 second to begin charging. The battery will now charge. Charge time 2-3 hours!

Mounting hole dimensions:

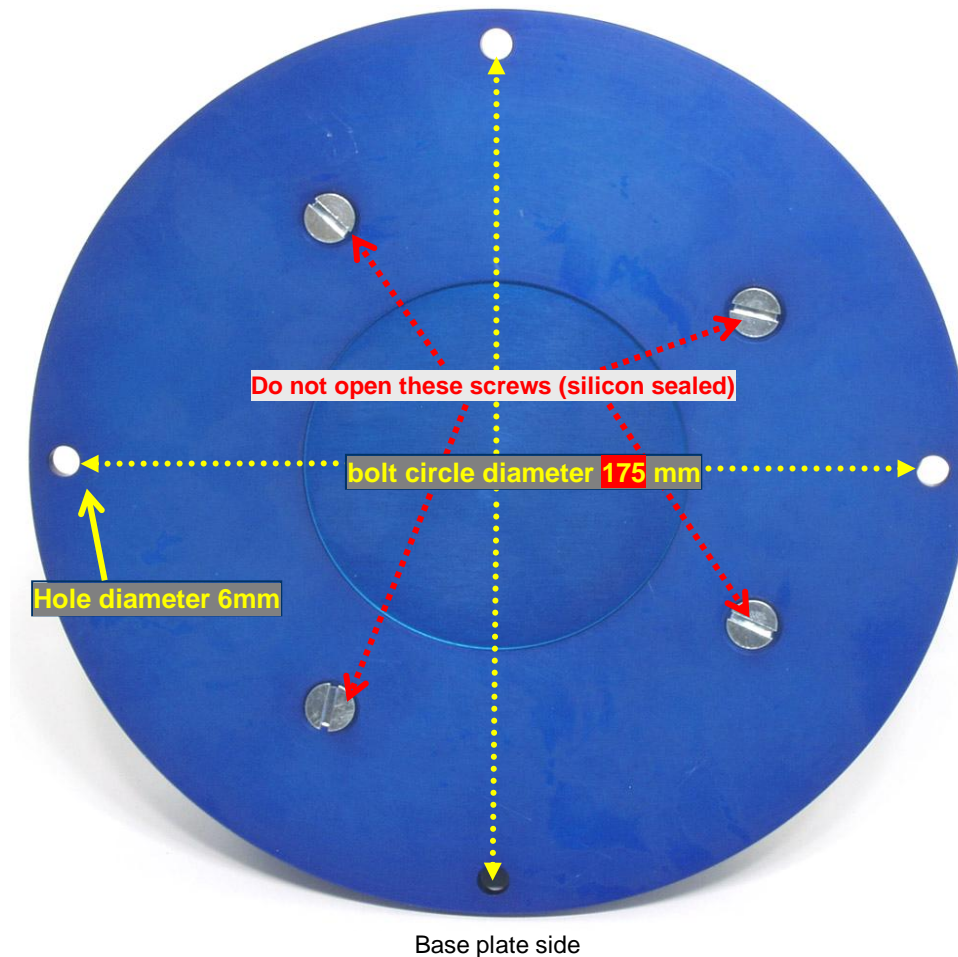

Dimensions:

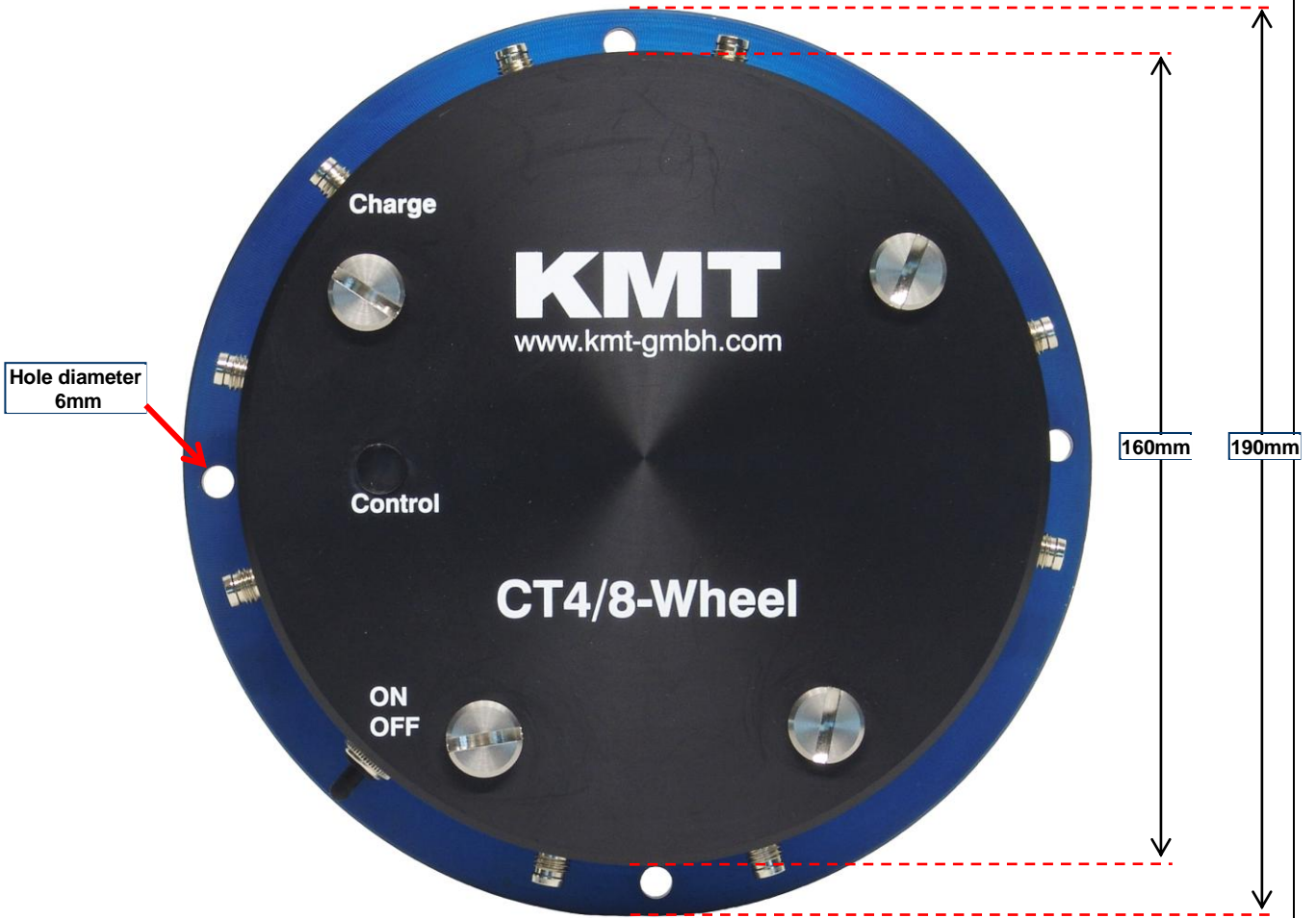

Height incl. screws 70mm
Total weight 1.5kg

Placing of receiving antennas:

